



GOOSENECK SURGE & SHIFT LOCK COUPLER INSTALLATION GUIDE

Patent #'s 11,370,257 B1 & D898,628



INSTALLATION - PIN STYLE

-On a level surface, take a vertical measurement from the bottom of the ball coupler tube to the bottom of the trailer frame sleeve and make note as you will transfer this measurement to your Shocker Hitch.

-Remove your original coupler tube (inner tube) by loosening the set bolt(s), pulling the safety pin, and sliding coupler tube out of the outer tube of your trailer.

-Take the Shocker Hitch and insert it into the outer tube of your trailer and re-install safety pin and set bolt(s). Please note for the standard red frame models, the air bag faces toward the rear of the trailer (see Figure 1). For the 9" offset model, the air bag faces toward the cab of your vehicle and the front of the trailer (see Figure 2).

-NOTES: Torque locking bolts to your trailer manufacturer's recommended specifications. Before hooking up to your towing vehicle, be sure to lubricate the Shift Lock coupler u-bolt and gooseneck ball in your bed. For proper usage of the Shift Lock coupler, please refer to "HOW TO USE SHIFT LOCK COUPLER" section.

-**IMPORTANT:** ALWAYS use safety chains with any gooseneck hitch as it is required by law in most states.

HOW TO USE SHIFT LOCK COUPLER

-Connect to the gooseneck ball by moving the Shift Lock coupler handle to the unlocked position (see Figure 3), lower the trailer onto the ball (see Figure 4), and move the Shift Lock coupler handle to the locked position and insert the quick clip pin. To check that the Shift Lock coupler is locked around the ball, you will see the u-bolt sticking out of the rear of the coupler approximately 1" (see Figure 5). If you do not see this, the coupler is NOT locked around the ball. Repeat the first two steps until you can see the u-bolt stick out the rear of the coupler in Figure 5.

INSTALLATION - CRANK HANDLE STYLE

-Remove 3/8" bolt and handle assembly from top of trailer. Loosen set screws and removed existing coupler stem. Remove bearing and 3/8" thick washer from the original stem and install on new Shocker Hitch stem. Add a generous amount of grease to and around the threaded shaft on the new stem. Carefully slide new Shocker Hitch stem up into the trailer until fully engaged and new crank stem is exposed at the top of the trailer, tighten set screws. Install one 3/8" thick washer on exposed crank stem.

NOTES: Ram brand couplers already have one, the Bulldog brand couplers will require the addition of a 3/8" thick washer which is supplied with the Shocker Hitch. Reinstall the crank handle with the 3/8" bolt, hook up trailer and adjust coupler for a level trailer. For proper coupler usage, please refer to "HOW TO USE SHIFT LOCK COUPLER" section of the instructions.

-**IMPORTANT:** ALWAYS use safety chains with any gooseneck hitch as it is required by law in most states.

SETTING AIR PRESSURE

-Initially set air pressure to around 15 PSI. Test driver and adjust air pressure in 5 PSI increments until optimum results are found. Decreasing/increasing air pressure may be needed. When towing in high winds, it may be necessary to increase the air bag air pressure.

-**IMPORTANT:** NEVER exceed 100 PSI in the air bag, this may lead to a stiffer ride and damage the air bag itself.

MAINTENANCE

-It is highly recommended that the hitch ball be greased to reduce wear. The Shocker Hitch should be greased regularly at the zerk located on the main pivot bolt. It is recommended to do every 6-12 months depending on the usage of the hitch. Note that you CANNOT over grease the pivot pin.



Figure 1: Standard red frame models the air bag faces toward the rear



Figure 2: 9" offset black frame models the air bag faces toward the front



Figure 3: Shift Lock coupler in unlocked position, lower hitch onto gooseneck ball



Figure 4: Shift Lock coupler lowered onto gooseneck ball

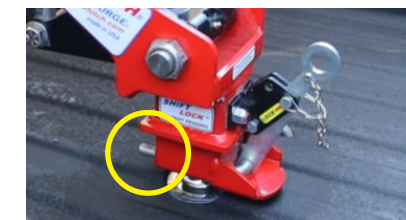
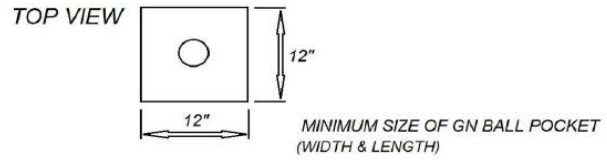
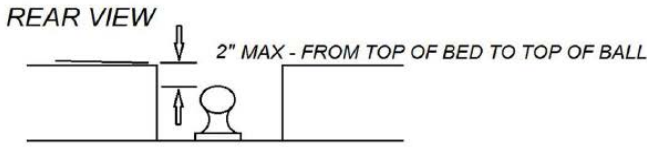

Figure 5: Shift Lock coupler in correct locked position - 1" of the u-bolt stick out

CONTINUED ON TO BACKSIDE

FITMENT DIMENSIONS FOR RECESSED BALLS IN A FLATBED POCKET



SHIFT LOCK COUPLER INSTALLATION - 3" COUPLERS

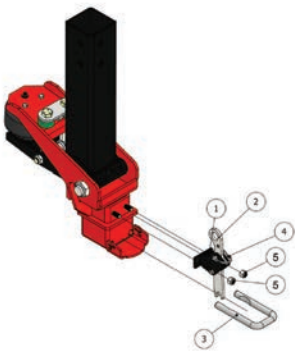

PARTS LIST		
ITEM	QTY	DESCRIPTION
1	1	SHIFT LOCK BRACKET
2	1	SHIFT LOCK HANDLE
3	1	U-BOLT COUPLER LOCK
4	1	SNAPPER PIN 3/8"ID x 1-1/2"
5	2	1/2-13" NC HEX NUT

•Ensure that the U-bolt (item 3) is inserted into the two bottom holes on the front of the Gooseneck Surge hitch just above the coupler guard (see Figure 1 & Figure 2).

•Take the Shift Lock assembly (contains items 1, 2, and 4) while keeping the U-bolt inserted, take the open end of the Shift Lock handle and place it center of the U-bolt. Slide the Shift Lock assembly onto the protruding bolts (see Figure 3 & Figure 4).

•Start the two nylon lock nuts (item 5) on the protruding through the Shift Lock bracket and tight them with a 3/4" socket. There should be NO play between the red frame of the Gooseneck Surge hitch and the Shift Lock bracket (see Figure 5 & Figure 6).

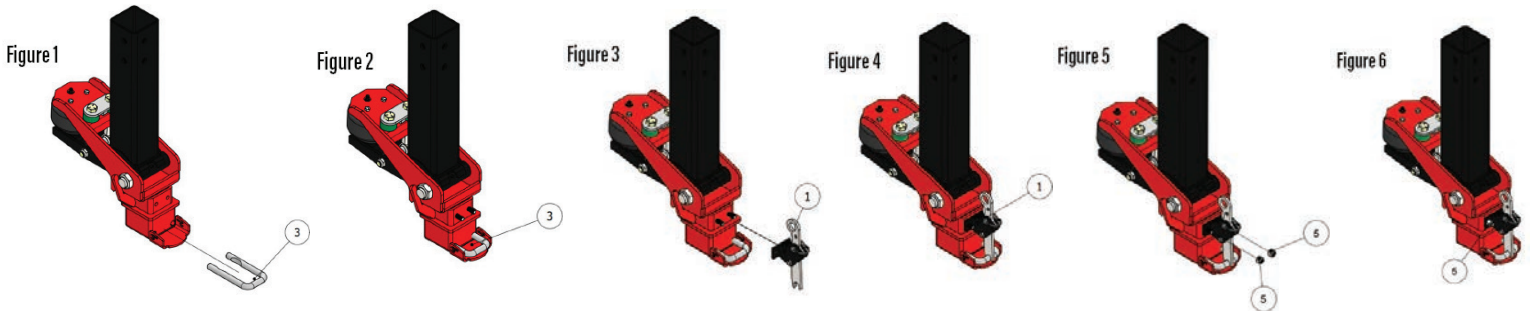

MAXIMUM WEIGHT RATINGS FOR SHOCKER GOOSENECK SURGE AIR HITCH MODELS

- 2-5/16" Coupler | Tow Capacity is 30,000 lbs for Shift Lock Coupler- 7,000 lbs tongue weight
- Shocker QuickAir 5th to Gooseneck | Tow capacity is 24,000 lbs GTW -6,000 lbs tongue weight
- 3" 40K Coupler | Towing capacity is 40,000 lbs for 3" Shift Lock Coupler- 8,000 lbs tongue weight

SAFETY NOTICE

The Shocker Hitch is a heavy duty unit, however it is imperative that any weight capacity ratings are not exceeded on the ball that is mounted on your tow vehicle, or the Shocker Hitch. Use only a 2 5/16" dia. Ball for 2-5/16" and use 3" ball for 3" coupler. V-19 rated. Always use safety chains with any goose neck hitch. Do NOT exceed Gross Vehicle Weight Rating, Gooseneck Ball Rating or Shocker Gooseneck Hitch weight ratings. We manufacture various stem configurations to fit most trailer manufactures. Please make sure you are using the correct one for your trailer. If you have ordered a "blank" stem with no holes, make sure you correctly mark pin location on the stem and have it drilled out by a professional qualified shop. Any modification to the hitch or coupler voids warranty and is done so at your own risk. Manufactured by Shocker Hitch® USA in Jamestown, ND.

ADDITIONAL INFORMATION

•Use your cell phone to scan the QR codes below for additional setup guides, air pressure guides, warranty registration, and our Shocker Hitch YouTube channel.



Set up guides



Air pressure guides



Warranty registration



YouTube channel

THANK YOU FOR CHOOSING SHOCKER HITCH AIR RIDE TOWING HITCHES

Shocker Hitch: Safer Smoother Towing - 2801 3RD AVE SW, JAMESTOWN ND, 58401 - (701)-707-2666

•Email: service@shockerhitch.com •Website: www.shockerhitch.com •Installation Videos on [Shocker Hitch](#) YouTube Channel